



EASA
European Aviation Safety Agency

EASA managed projects

**Helicopter Safety Research
Management Committee**

24 Feb 2016

Your safety is our mission.

EASA is an agency of the European Union





MGH



**London
South Bank
University**

with

Cranfield
UNIVERSITY

Main Gearbox Health (MGH)



G-PUMI UNKG-2010-027

It is recommended that the European Aviation Safety Agency, with the assistance of the Civil Aviation Authority, conduct a review of options for extending the scope of Health and Usage monitoring Systems (HUMS) detection into the rotating systems of helicopters.



G-REDL UNKG-2011-041

It is recommended that the European Aviation Safety Agency research methods for improving the detection of component degradation in helicopter epicyclic planet gear bearings.



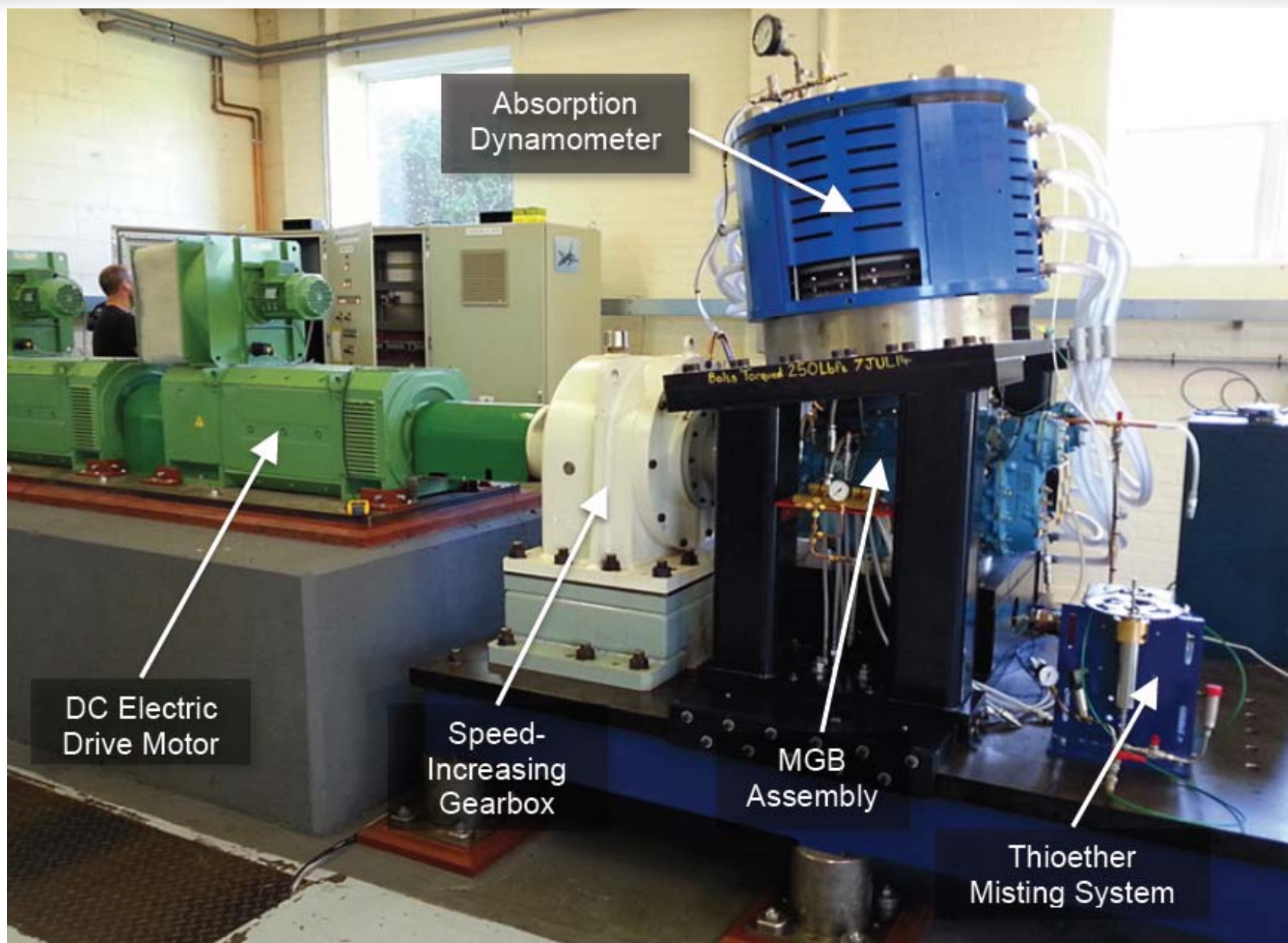





Thioether Mist Lubrication



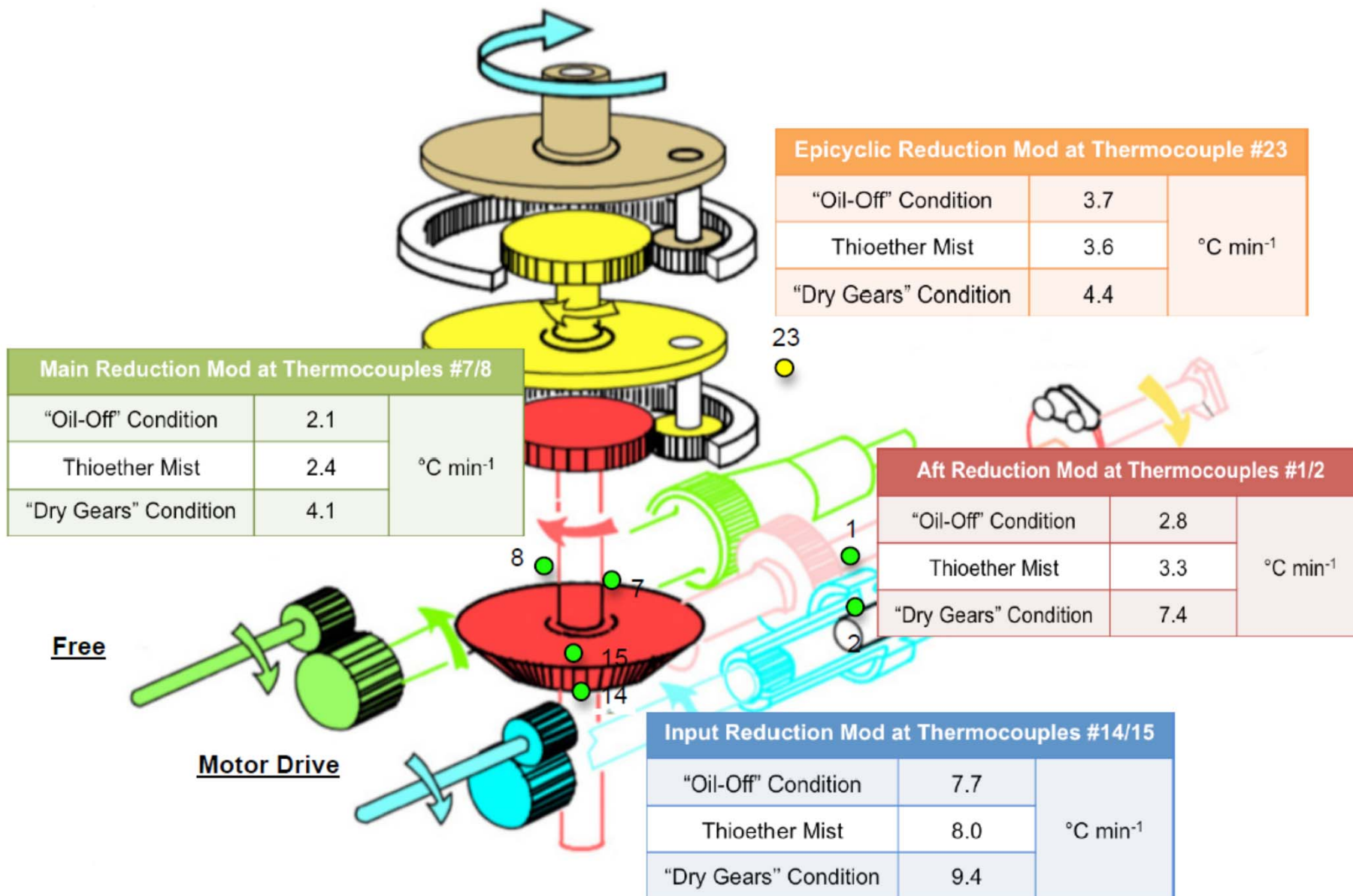

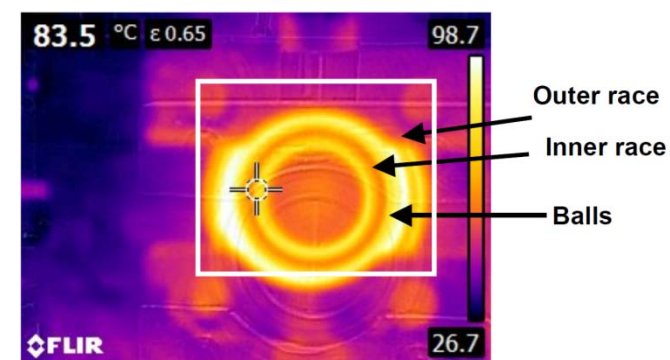
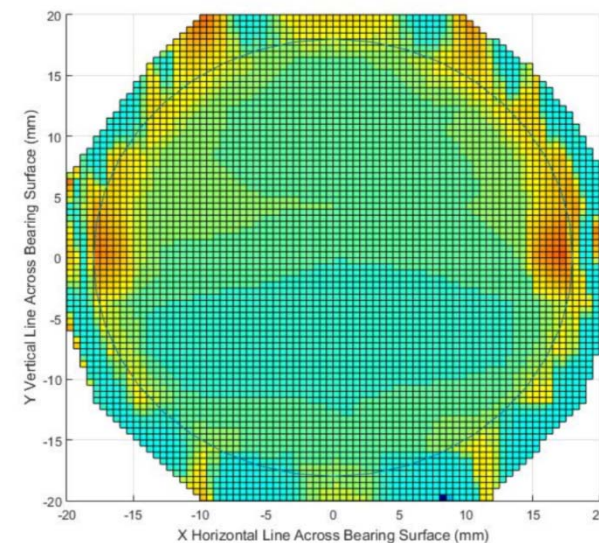
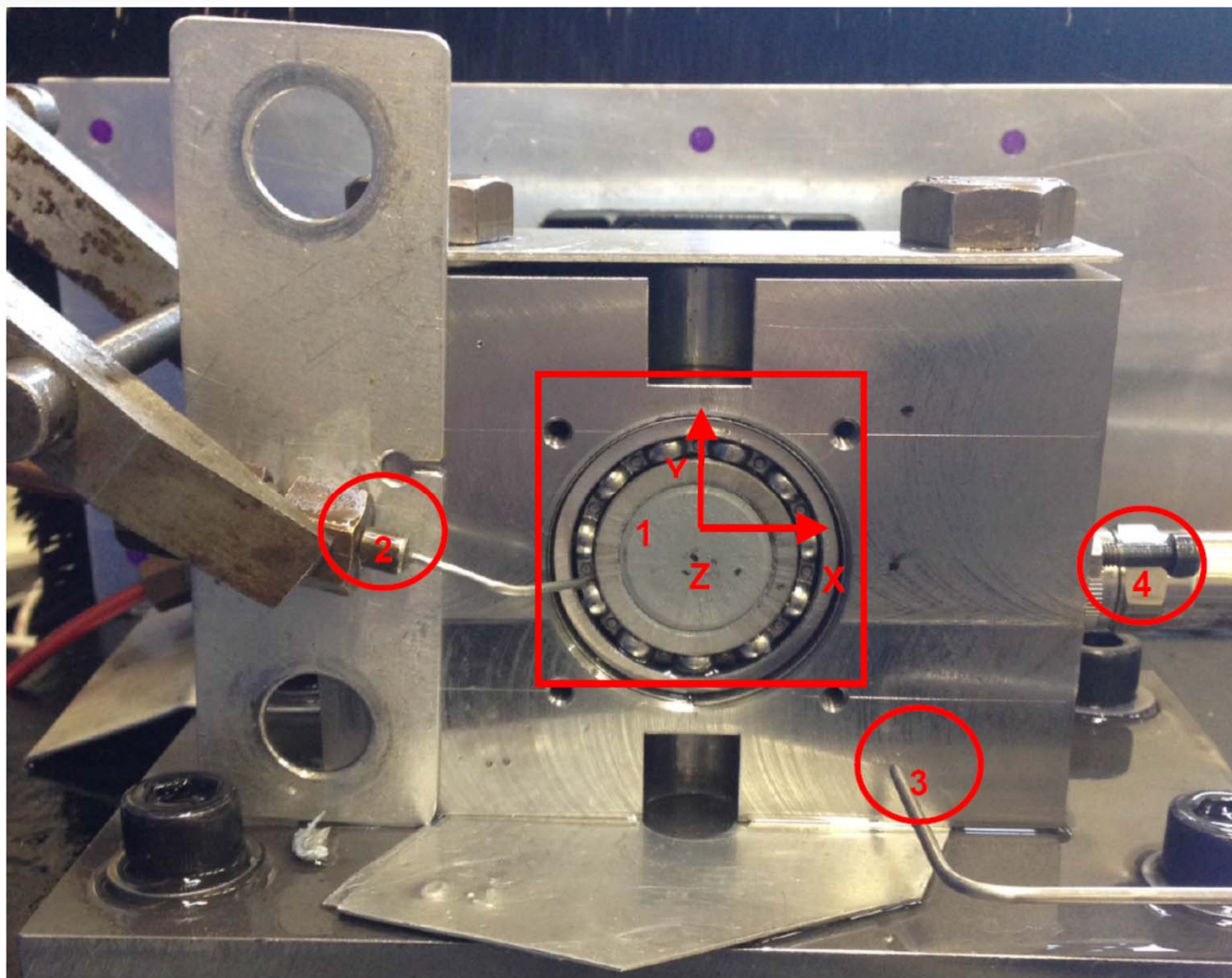

► Windage test rig

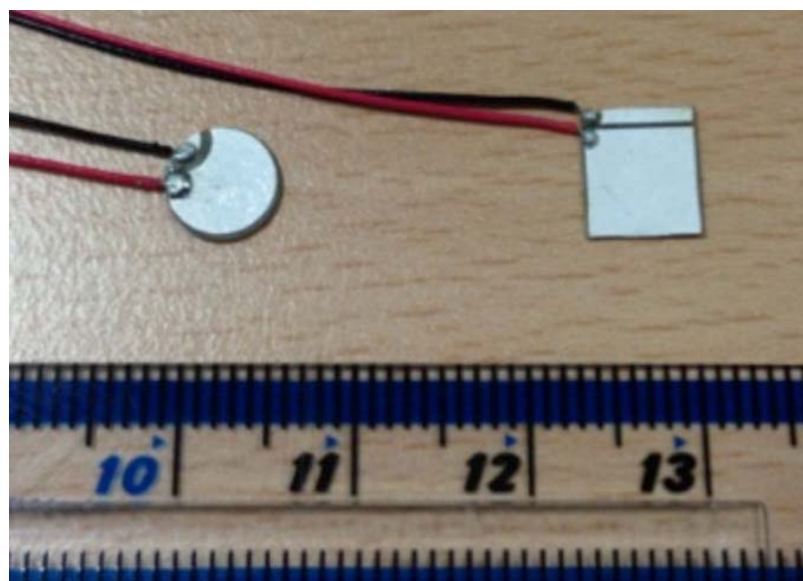

► **Acoustic Emission sensor installed**

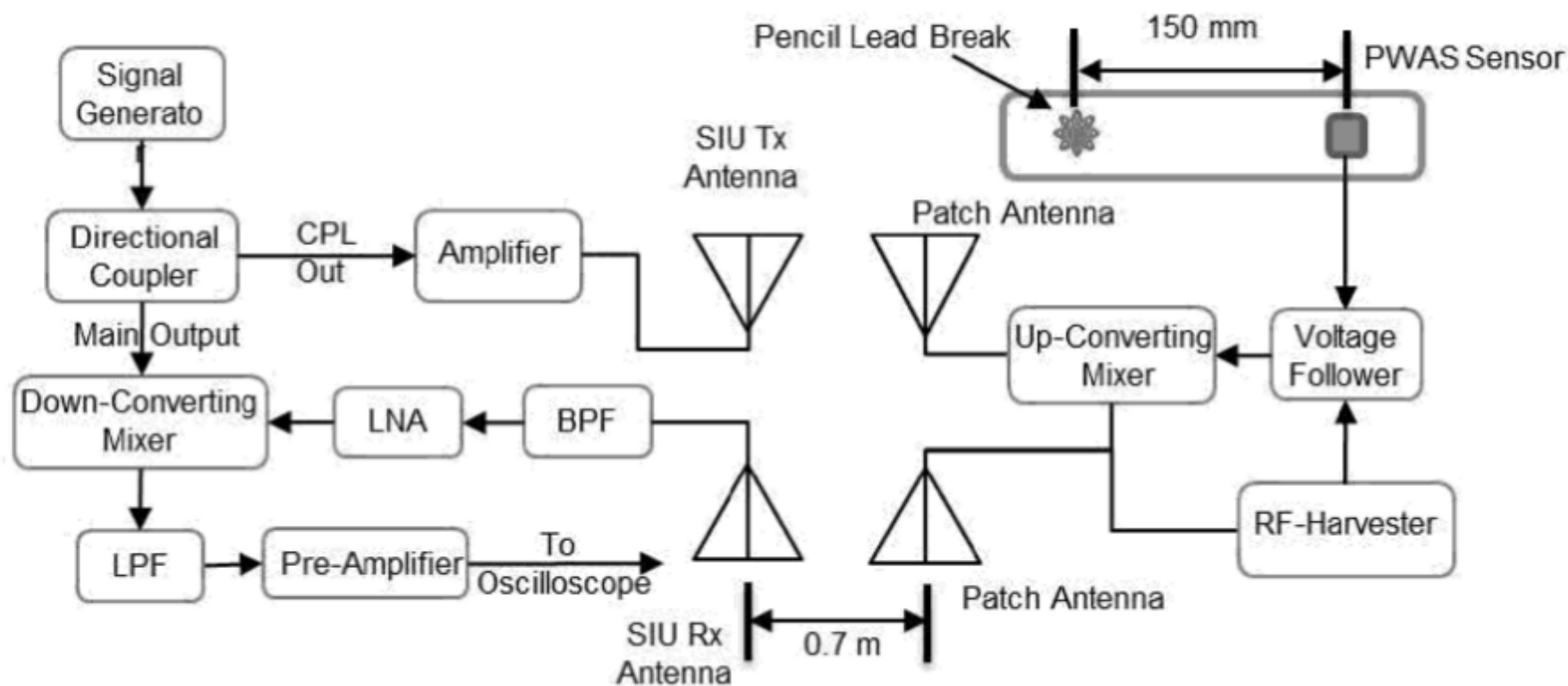

Fig: Analogue AE Wireless Transmission System, developed by H.Huang and F. Zahedi

Source: F. Zahedi, H. Huang, 'Wireless Acoustic Emission sensor powered by microwave energy'.



Review of practices for Helicopter North Sea Operations

➤ Objectives

- Develop a comprehensive knowledge base of current practices for North Sea operations
- Focus on safety management
- Recommendations for the promotion of identified good/best practices

➤ Scope

- Passenger transport
- Offshore flights
- Covering safety risk management for all phases of flight



Review of practices for Helicopter North Sea Operations

- Contract awarded to DNV GL (UK)
- Timeframe: Sept 2015 – Sept 2016
- Currently on-going: surveys, interviews for UK, NO, NL, DK
- Organizations contacted: Operators, Pilot union, NAAs, Oil & Gas industry bodies
- 2 technical workshops planned to discuss project results in 2016 (dates not yet confirmed)



- ▶ EASA's mandate in current Basic Regulation:
 - ▶ The Agency may develop and finance research in the field of its competence,
 - ▶ The Agency shall coordinate its research activities,
 - ▶ The results of research shall be published
 - ▶) " ... Commission and EASA ... shall take into account the latest scientific and technical evidence"
- ▶ Agency's research priorities are set by the EPAS
- ▶ A-NPA 2014-12 revision of Basic Regulation
 - ▶ Stakeholders support strengthened EASA role in research coordination



EU Research activities for Aviation:

- Fragmented : multiple projects – initiatives – levels (EU, national, industry)
- Low reactivity to ‘burning’ issues
- Low visibility of achievements
- Difficult to follow-up and to deploy
- Comparison with US
 - More resources: EASA: 500 kEuro versus FAA: 95 MEuro
 - More flexible



- Research areas of outstanding relevance
 - Lithium Batteries
 - Cabin air quality
 - Flight time limitation
 - Remotely piloted aircraft systems
- EASA approach for Horizon 2020 work progr.
 - Operational safety issues, e.g. loss of control in flight
 - Changes to standards, e.g. composite materials, cyber sec.
 - Systematic issues, e.g. big data analysis for safety
 - Human factors issues
 - Emerging safety issues



► Crew immersion suits conspicuity





► Ultrasonic inspection of Gearboxes – ScanEcho - Peter Sharp

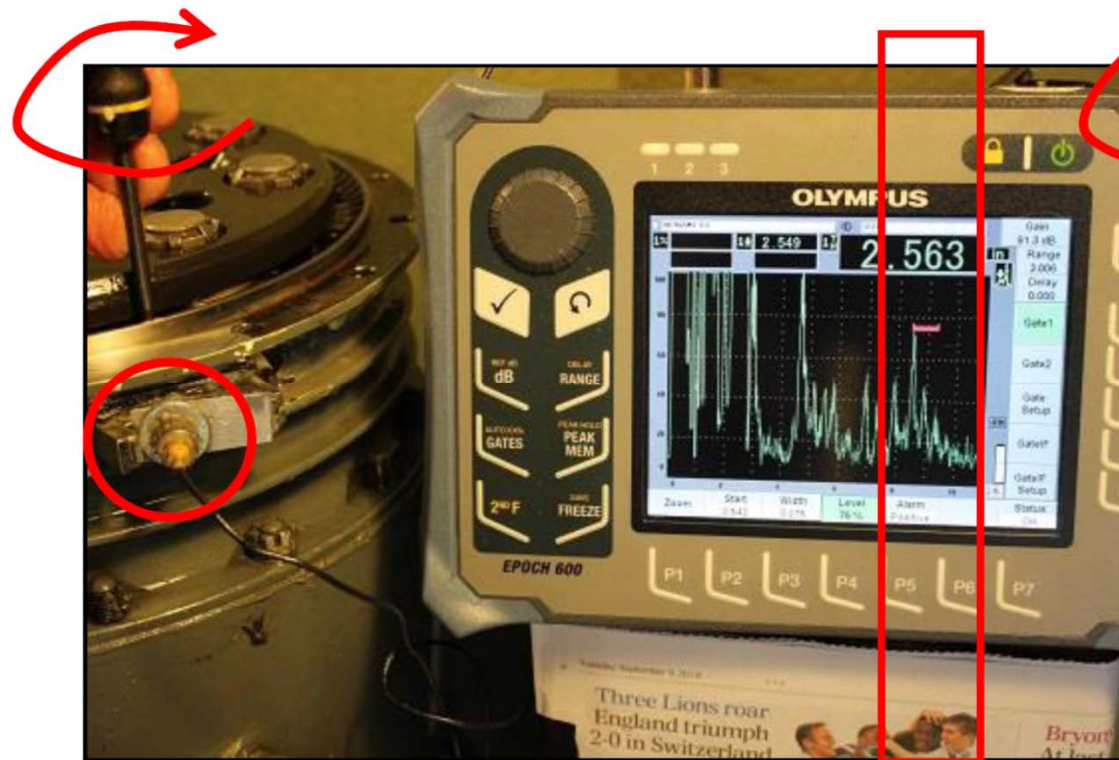



EASA
European Aviation Safety Agency

Questions?

Your safety is our mission.

EASA is an agency of the European Union

